

REVISIONS			
Rev. No:	Revizyon Açıklama	Tarih	Onay
01			
02			

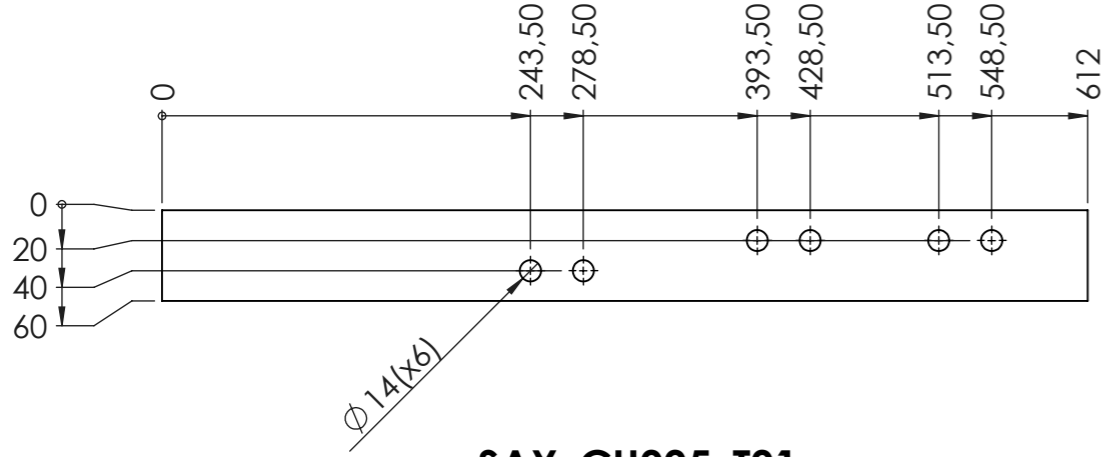

SAY_CU005_T01
2000A Çıkış Bakırı - 1 (L1)

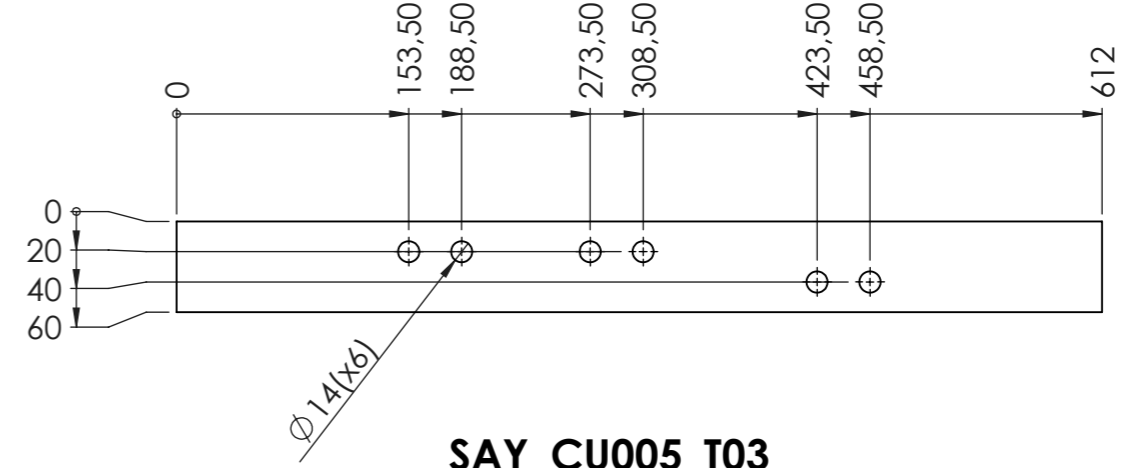

SAY_CU005_T03
2000A Çıkış Bakırı - 1 (L3)

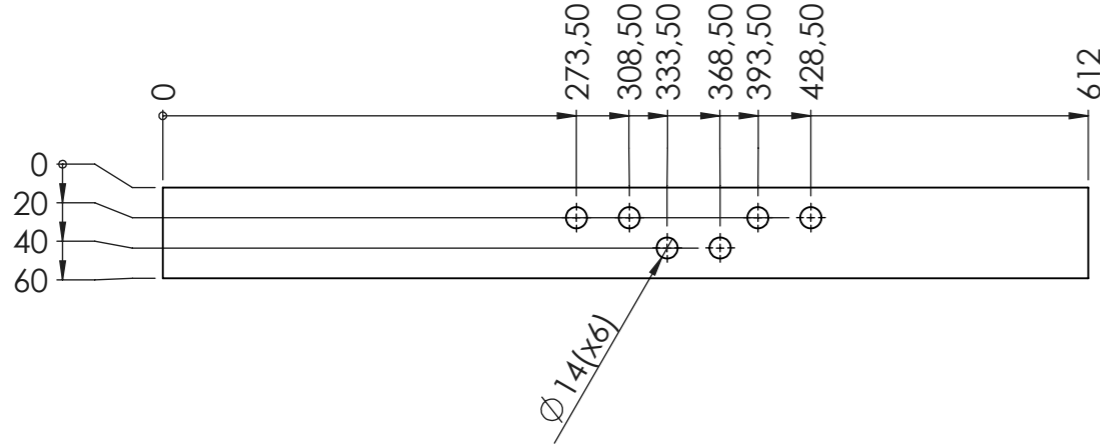

SAY_CU005_T02
2000A Çıkış Bakırı - 1 (L2)

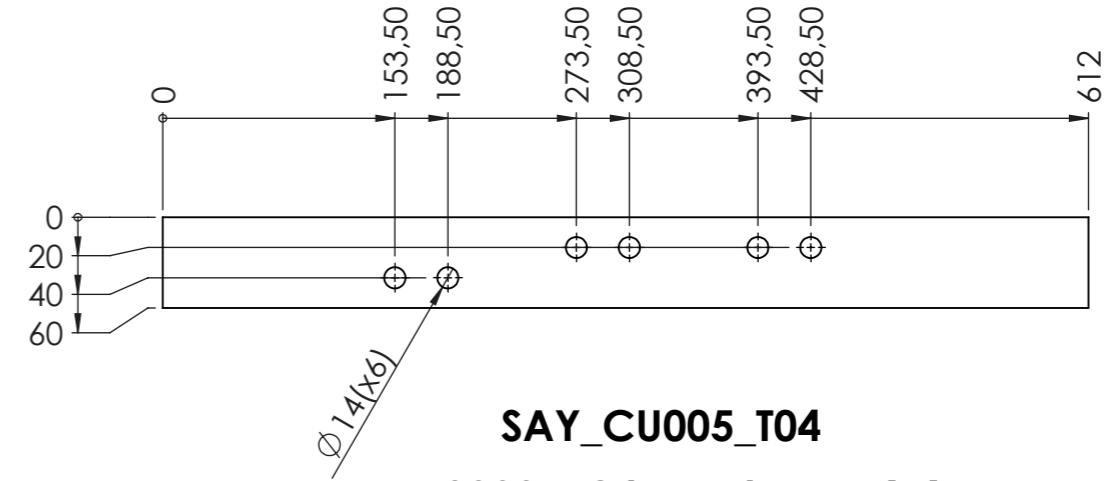

SAY_CU005_T04
2000A Çıkış Bakırı - 1 (N)

Operasyon Sıralaması;
1. BAKIR KESİM
2. BAKIR DELİK DELME
3. BAKIR BÜKÜM

Büküm Radius = 10 mm
Büküm Uzama Değeri = -18 mm (90 deg.)
Tüm Toleranslar : ±1 mm

Resim No: / Code	SAY_CU005		SAY OTOMASYON			
Resim Adı: / Title	ABB 4P 2000A - 4P 4x630A Bakırları					
Malzeme / Material :	Copper	Ağır. / Weight:	kg	Alan / Area:	m ²	
Çizen / Drafted:	Ahmet ÇETİN	01.03.2017	Ölç. / Sc.	Rev.: 00	A4 S.No:7 /1	
Onay / Approved:	M. ÇOPUR	01.03.2017			mm TR	

REVISIONS			
Rev. No:	Revizyon Açıklama	Tarih	Onay
01			
02			

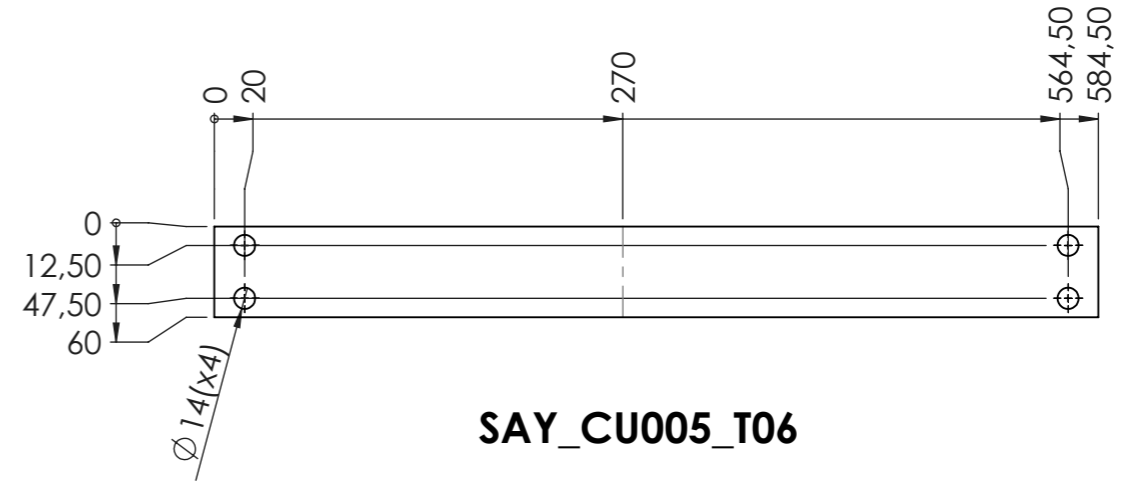
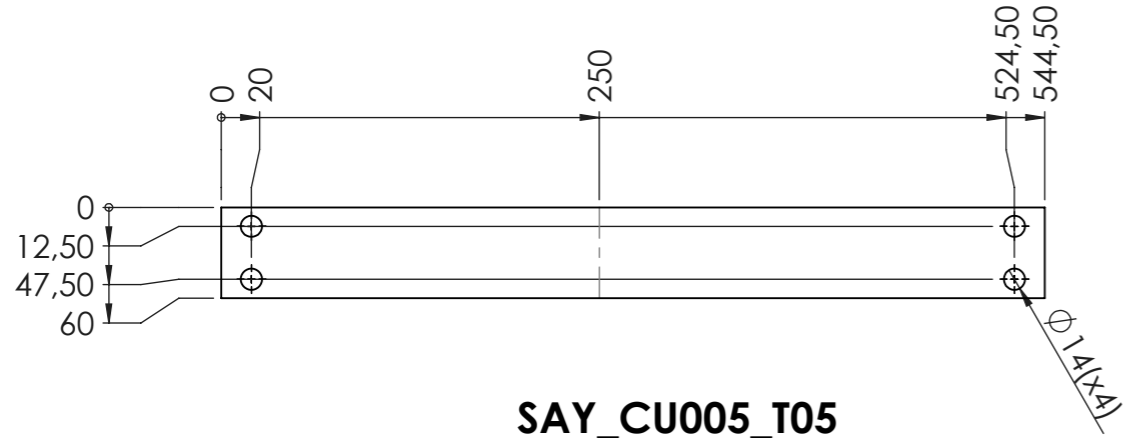
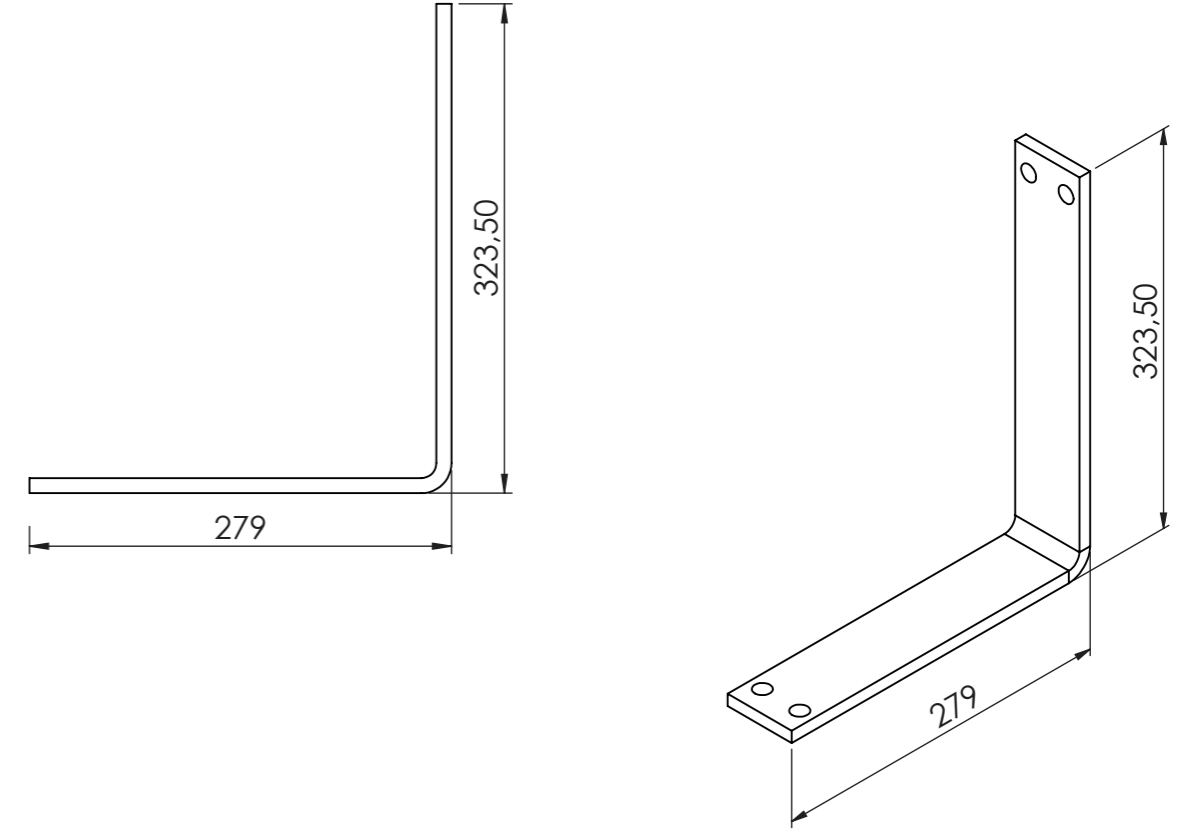
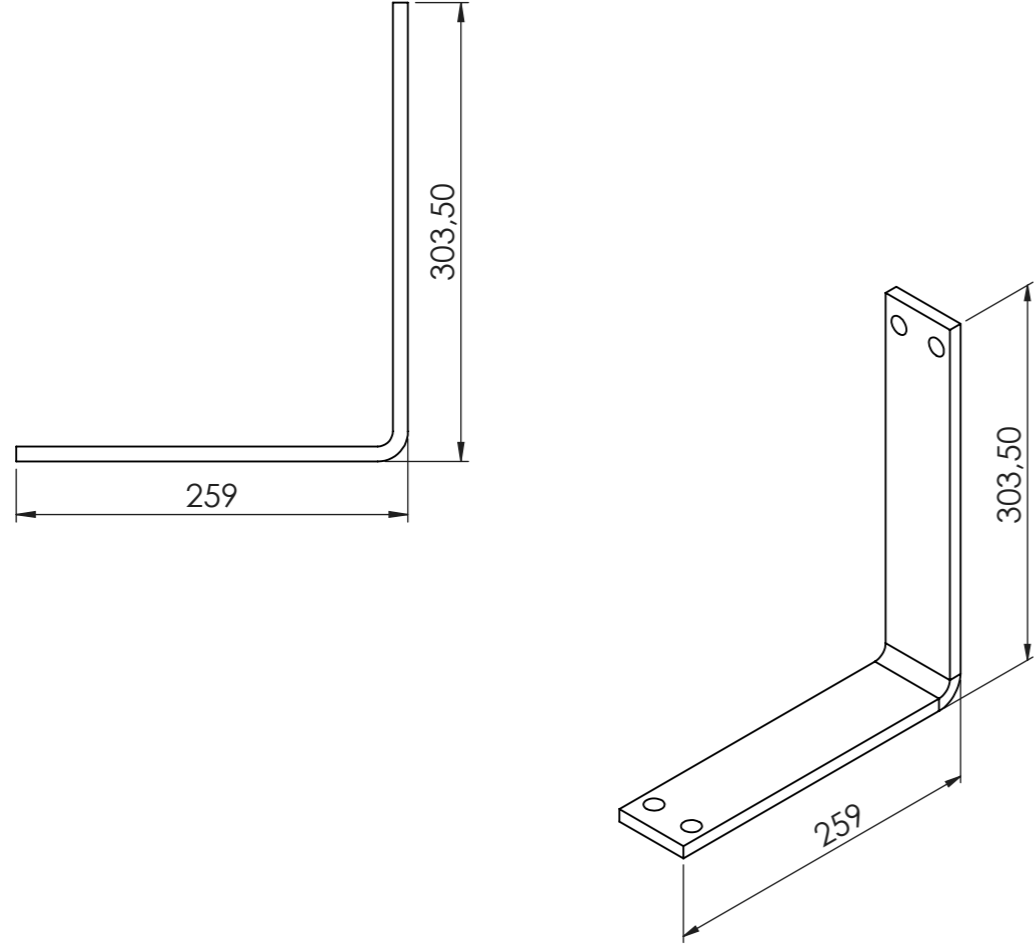

SAY_CU005_T05

SAY_CU005_T06

- Operasyon Sıralaması;**
1. BAKIR KESİM
2. BAKIR DELİK DELME
3. BAKIR BÜKÜM

Büküm Radius = 10 mm
Büküm Uzama Değeri= -18 mm (90 deg.)
Tüm Toleranslar : ±1 mm

Resim No: / Code	SAY_CU005		SAY OTOMASYON			
Resim Adı: / Title	ABB 4P 2000A - 4P 4x630A Bakırları					
Malzeme / Material :	Copper	Ağır. / Weight:	kg	Alan / Area:	m ²	
Çizen / Drafted:	Ahmet ÇETİN	01.03.2017	Ölç. / Sc.	Rev.: 00	A4	S.No:7 /2
Onay / Approved:	M. ÇOPUR	01.03.2017			mm	TR

REVISIONS			
Rev. No:	Revizyon Açıklama	Tarih	Onay
01			
02			

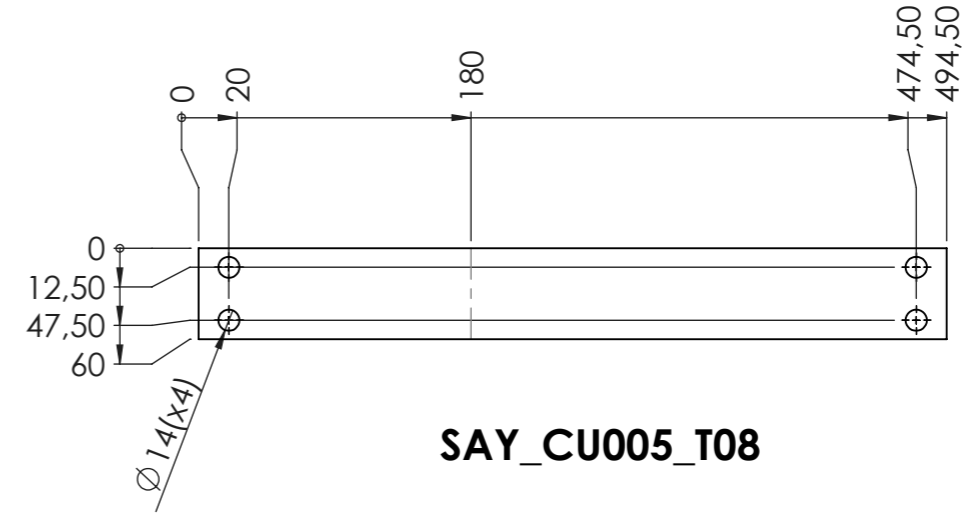
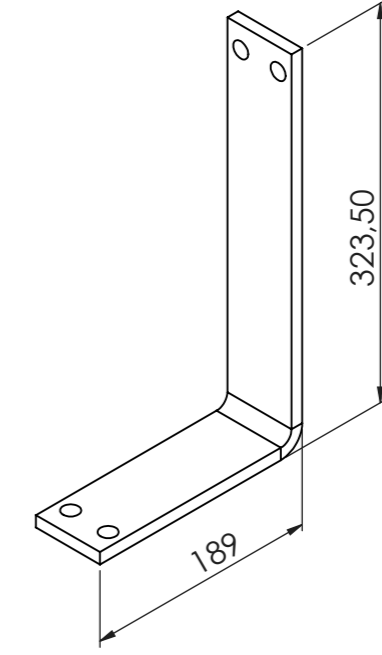
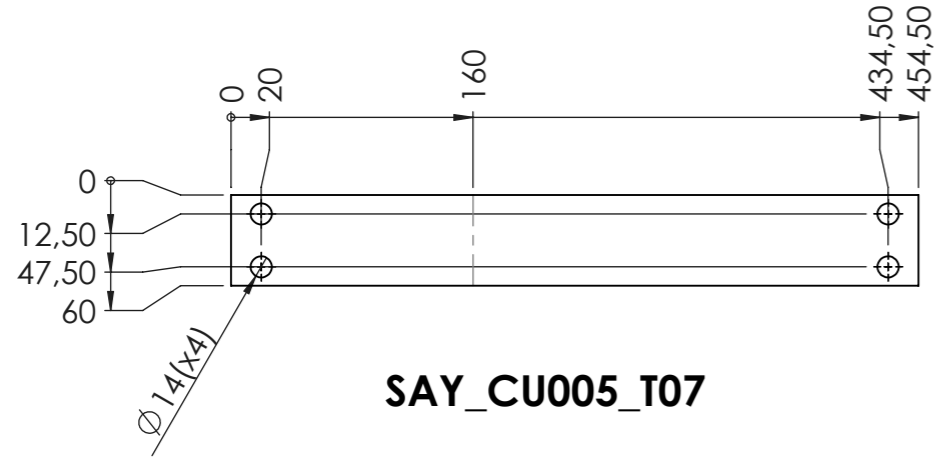
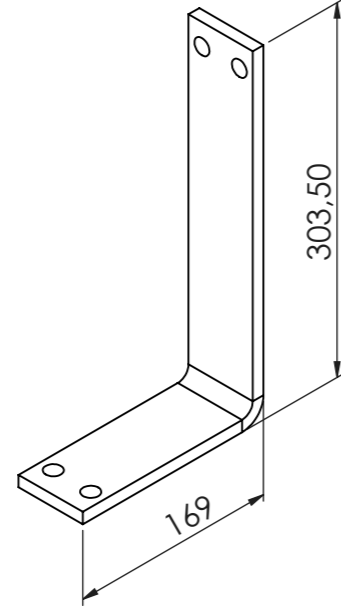

- Operasyon Sıralaması;**
1. BAKIR KESİM
2. BAKIR DELİK DELME
3. BAKIR BÜKÜM

Büküm Radius = 10 mm
Büküm Uzama Değeri= -18 mm (90 deg.)
Tüm Toleranslar : ±1 mm

Resim No: / Code	SAY_CU005		SAY OTOMASYON			
Resim Adı: / Title	ABB 4P 2000A - 4P 4x630A Bakırları					
Malzeme / Material :	Copper	Ağır. / Weight:	kg	Alan / Area:	m ²	
Çizen / Drafted:	Ahmet ÇETİN	01.03.2017	Ölç. / Sc.	Rev.: 00	A4	S.No:7 /3
Onay / Approved:	M. ÇOPUR	01.03.2017			mm	TR

REVISIONS			
Rev. No:	Revizyon Açıklama	Tarih	Onay
01			
02			

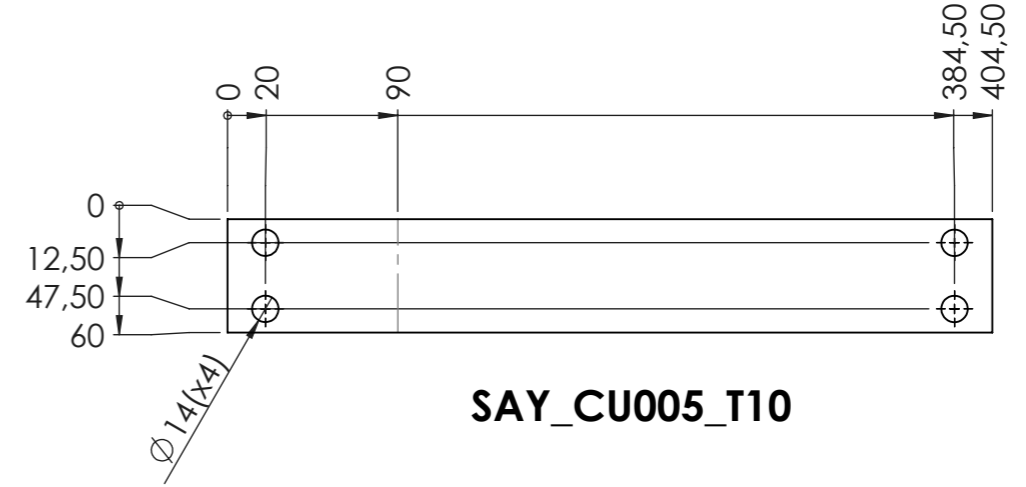
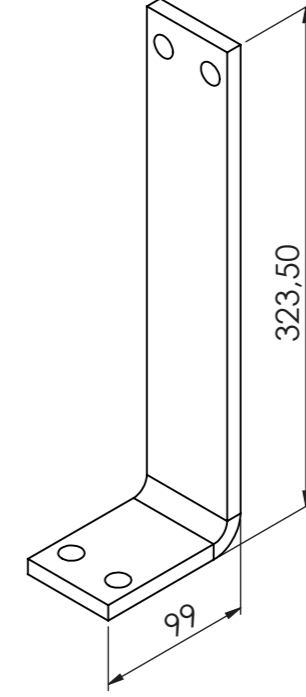
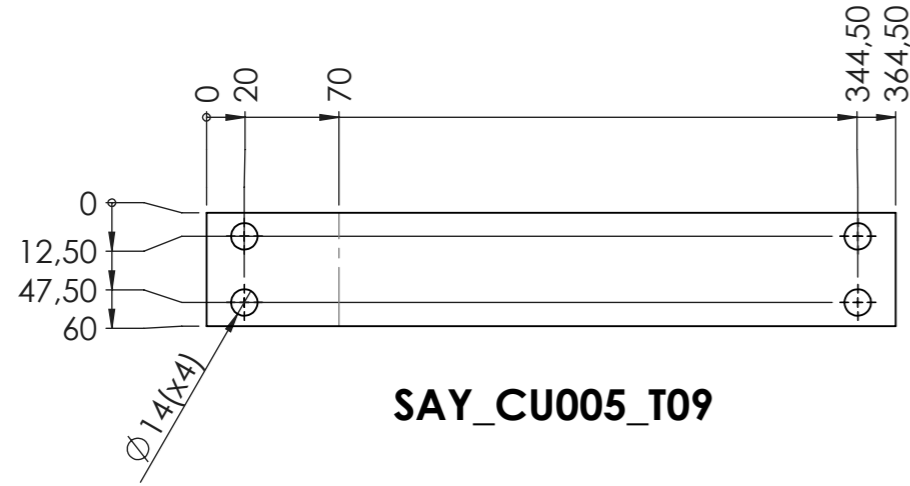
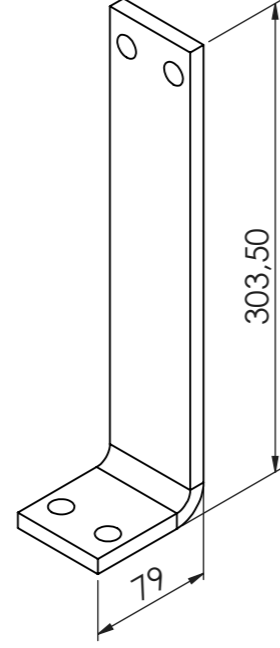

- Operasyon Sıralaması;**
1. BAKIR KESİM
 2. BAKIR DELİK DELME
 3. BAKIR BÜKÜM

Büküm Radius = 10 mm
 Büküm Uzama Değeri= -18 mm (90 deg.)
 Tüm Toleranslar : ±1 mm

Resim No: / Code	SAY_CU005		SAY OTOMASYON			
Resim Adı: / Title	ABB 4P 2000A - 4P 4x630A Bakırları					
Malzeme / Material :	Copper	Ağır. / Weight:	kg	Alan / Area:	m ²	
Çizen / Drafted:	Ahmet ÇETİN	01.03.2017	Ölç. / Sc.	Rev.: 00	A4	S.No:7 /4
Onay / Approved:	M. ÇOPUR	01.03.2017			mm	TR

REVISIONS			
Rev. No:	Revizyon Açıklama	Tarih	Onay
01			
02			

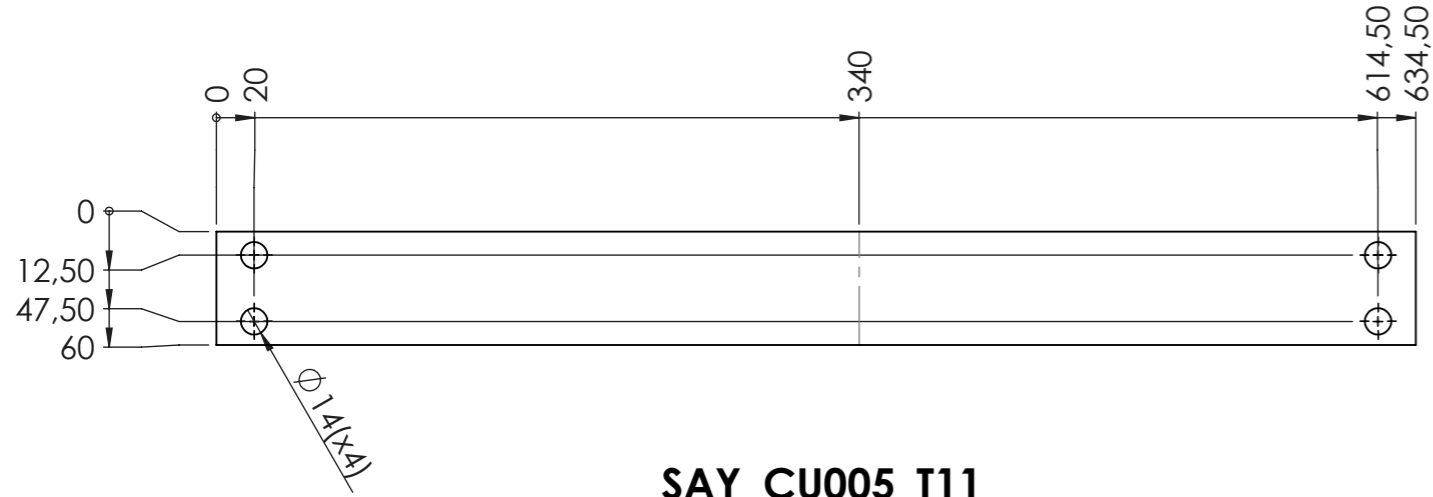
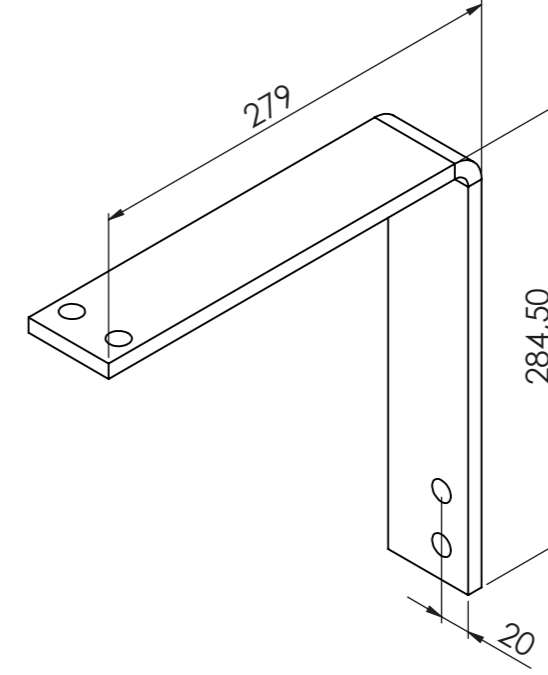
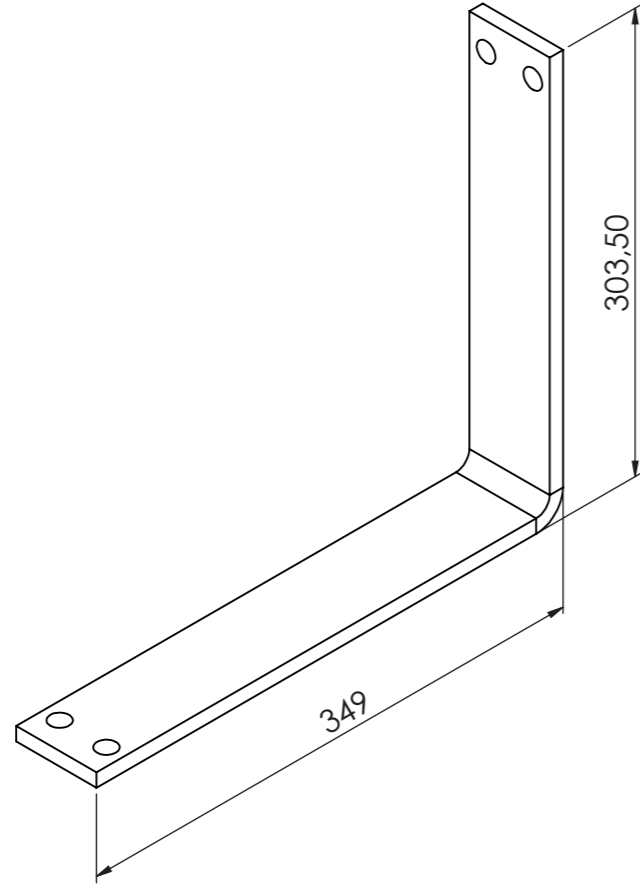

SAY_CU005_T11

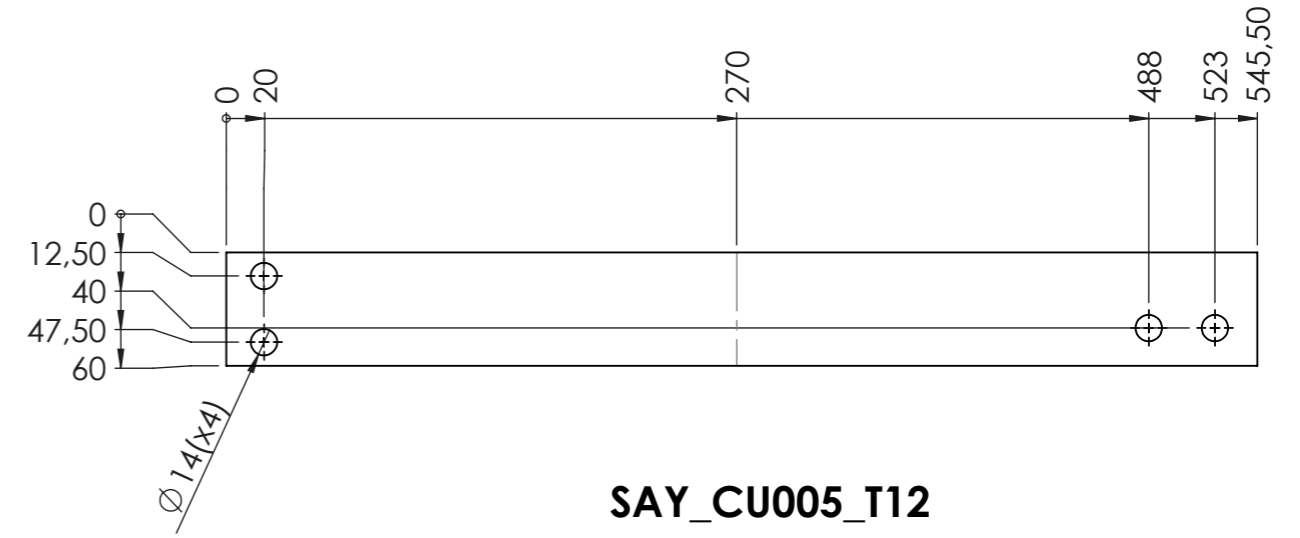

SAY_CU005_T12

- Operasyon Sıralaması;**
1. BAKIR KESİM
2. BAKIR DELİK DELME
3. BAKIR BÜKÜM

Büküm Radius = 10 mm
Büküm Uzama Değeri = -18 mm (90 deg.)
Tüm Toleranslar : ±1 mm

Resim No: / Code	SAY_CU005		SAY OTOMASYON			
Resim Adı: / Title	ABB 4P 2000A - 4P 4x630A Bakırları					
Malzeme / Material :	Copper	Ağır. / Weight:	kg	Alan / Area:	m ²	
Çizen / Drafted:	Ahmet ÇETİN	01.03.2017	Ölç. / Sc.	Rev.: 00	A4	S.No:7 /5
Onay / Approved:	M. ÇOPUR	01.03.2017			mm	TR

REVISIONS			
Rev. No:	Revizyon Açıklama	Tarih	Onay
01			
02			

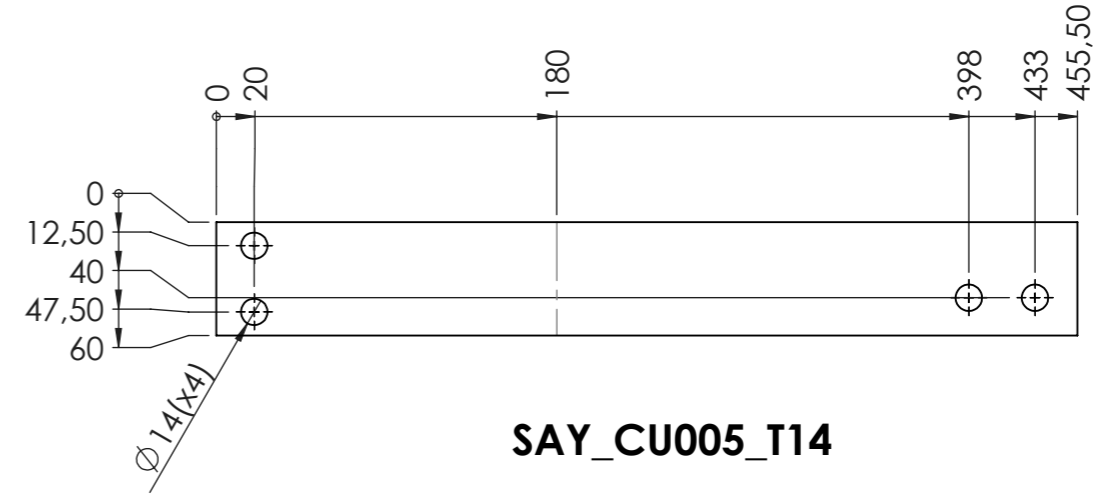
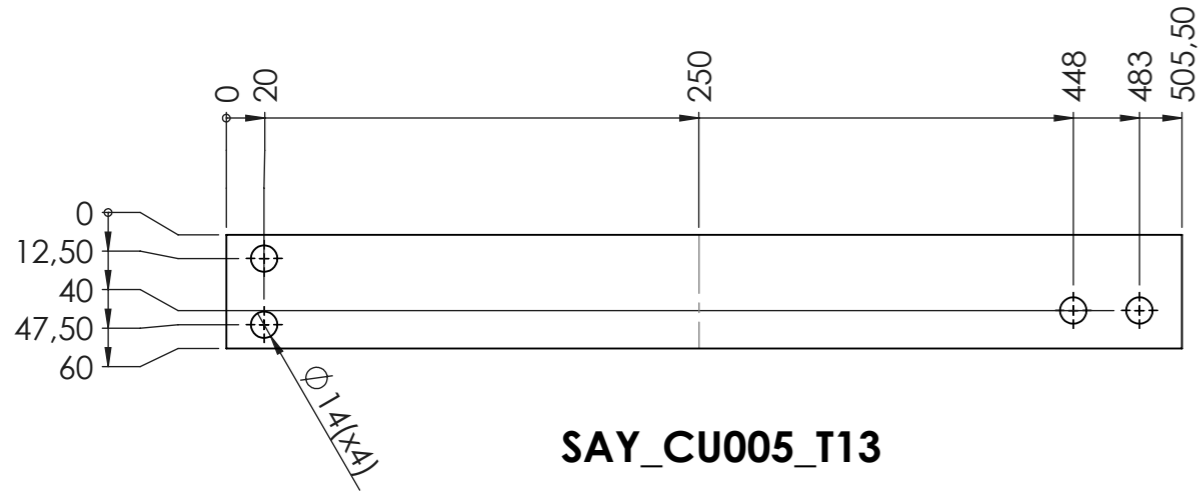
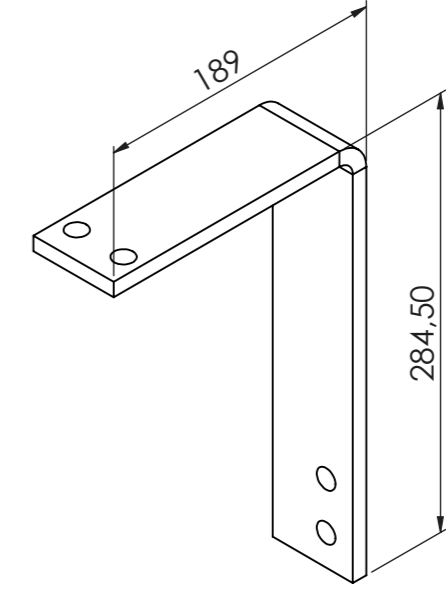
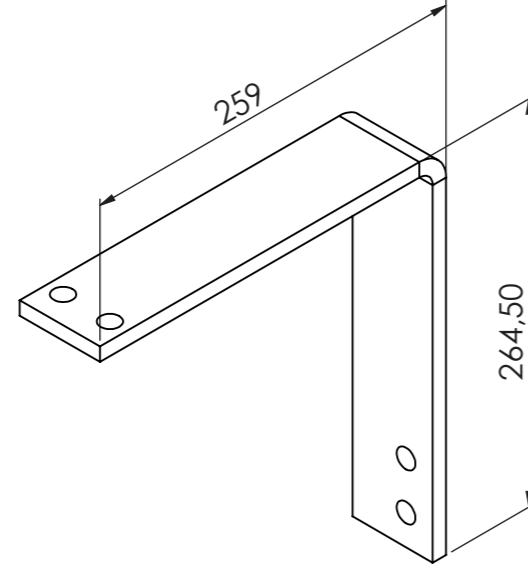

- Operasyon Sıralaması;**
1. BAKIR KESİM
2. BAKIR DELİK DELME
3. BAKIR BÜKÜM

Büküm Radius = 10 mm
Büküm Uzama Değeri= -18 mm (90 deg.)
Tüm Toleranslar : ±1 mm

Resim No: / Code	SAY_CU005		SAY OTOMASYON			
Resim Adı: / Title	ABB 4P 2000A - 4P 4x630A Bakırları					
Malzeme / Material :	Copper	Ağır. / Weight:	kg	Alan / Area:	m ²	
Çizen / Drafted:	Ahmet ÇETİN	01.03.2017	Ölç. / Sc.	Rev.: 00	A4	S.No:7 /6
Onay / Approved:	M. ÇOPUR	01.03.2017			mm	TR

REVISIONS			
Rev. No:	Revizyon Açıklama	Tarih	Onay
01			
02			

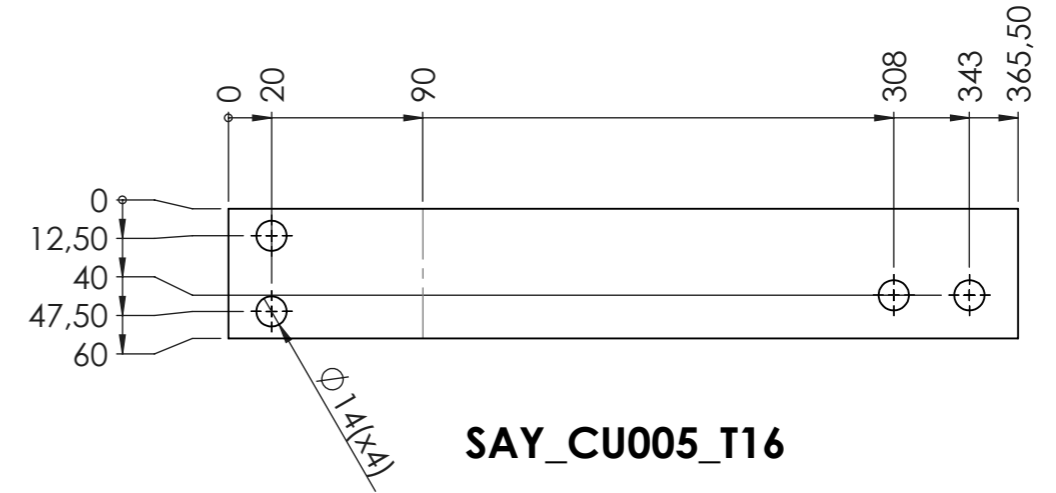
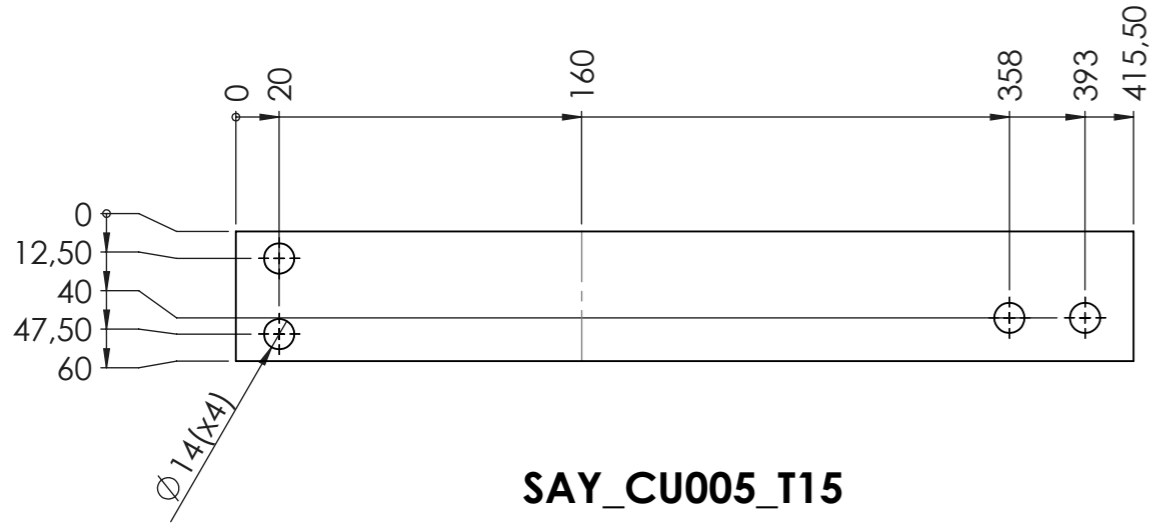
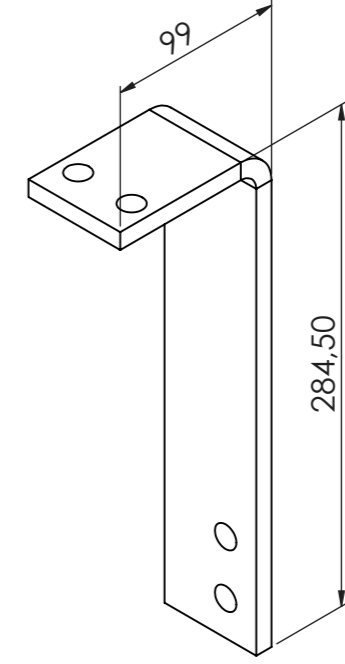
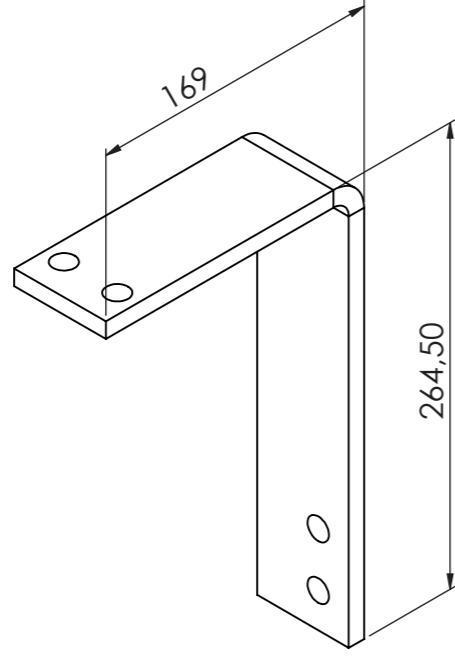

- Operasyon Sıralaması;**
1. BAKIR KESİM
 2. BAKIR DELİK DELME
 3. BAKIR BÜKÜM

Büküm Radius = 10 mm
 Büküm Uzama Değeri = -18 mm (90 deg.)
 Tüm Toleranslar : ±1 mm

Resim No: / Code	SAY_CU005		SAY OTOMASYON			
Resim Adı: / Title	ABB 4P 2000A - 4P 4x630A Bakırları					
Malzeme / Material :	Copper	Ağır. / Weight:	kg	Alan / Area:	m ²	
Çizen / Drafted:	Ahmet ÇETİN	01.03.2017	Ölç. / Sc.	Rev.: 00	A4	S.No:7 / 7
Onay / Approved:	M. ÇOPUR	01.03.2017			mm	TR